

## Level Limiting With CAN Bus, CANopen Protocol **NRG 16-40, NRG 17-40, NRG 19-40**

### Description

The level electrodes NRG 1...-40 work according to the conductivity measurement principle and detect the min. level in electrically conductive liquids:

- One level alarm with **one** switchpoint

Use level electrode NRG 1...-40 in combination with level switch NRS 1-40 or NRS 1-40.1 and/or other system components. The NRG 1...-40 in conjunction with its associated control equipment constitutes a water level limiter with periodic self-testing routine (SMART function) in accordance with TRD 604, sheet 1 and 2 and EN regulations. The level data are transferred from the electrode NRG 1...-40 to the control unit via a CAN bus using the CANopen protocol.

### Function

The electrode operation is based on the conductive measuring principle using the electrical conductivity for signalling liquid levels. Some liquids are conductive, which means that they allow an electric current to flow through them. For the safe functioning of this device a minimum conductivity of the liquid to be monitored is required.

The conductivity measurement method can detect two conditions: electrode rod submerged or exposed, meaning switchpoint reached (or exceeded) or not yet reached. Before installation, the electrode rod must be cut to length to give the required low-level alarm and effect the consequent cut-out of the burner circuit.

The system incorporates an additional electrode that provides automatic monitoring of the electrical resistance path between the measuring electrode and the earth. When the measured value falls below the admissible resistance value the burner shutdown is endorsed by interruption of the burner protection circuit.

At regular intervals, the level electrode NRG 1...-40 sends a data telegram to the controller NRS 1-40. The data transfer is effected by means of a CAN bus according to DIN ISO 11898 adopting the CANopen protocol. **One** controller type NRS 1-40 can be used for **two** level electrodes NRG 1...-40 (**low-level limiter arrangement**).

### Design

Screwed 3/4" BSP to EN ISO 228-1

### Technical Data

#### Type approval no.

TÜV · SWB / SHWS · 07-403  
EG BAF-MUC 02 02 103881 002

#### Service pressure

NRG 16-40, PN 40, 32 bar g (464 psig) at 238 °C  
NRG 17-40, PN 63, 60 bar g (870 psig) at 275 °C  
NRG 19-40, PN 160, 100 bar g (1450 psig) at 311 °C

#### Connection

Screwed BSP 3/4", EN ISO 228-1

#### Materials

Terminal box: 3.2161 G AISi8Cu3  
Stem: 1.4571, X6CrNiMoTi17-12-2  
Measuring electrode: 1.4401, X5CrNiMo17-12-2  
Electrode insulation: Gylon®

#### Lengths supplied

500 mm, 1000 mm, 1500 mm,  
2000 mm, 2500 mm, 3000 mm

#### Sensitivity

> 0.5 µS/cm at 25°C

#### Supply voltage

18–36 V DC (coming from NRS 1-40 / NRS 1-40.1)

#### Current consumption

35 mA

#### Fuse

Thermal fuse  $T_{max} = 85 °C$ , hysteresis 2 K

#### Hysteresis

-2 K

#### Electrode voltage

$2 V_{SS}$

#### Data exchange

CAN bus to DIN ISO 11898, CANopen protocol

– continued – P.T.O.

### Wiring Diagram

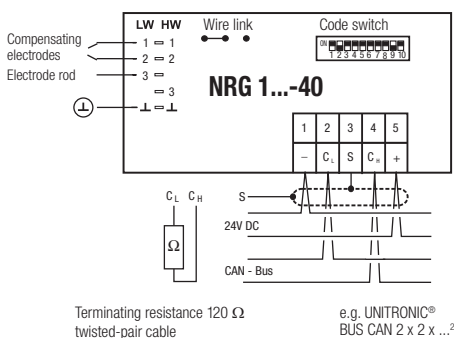

### Important Note

Note that screened multi-core twisted-pair control cable is required for the BUS line, e. g. UNITRONIC® BUS CAN 2 x 2 x ... mm<sup>2</sup> or RE-2YCYV-fl 2 x 2 x ... mm<sup>2</sup>.

Prefabricated control cables (with connector and coupler) of various lengths for connecting the equipment are available as accessories. The baud rate (data transfer rate) dictates the cable length between the bus nodes and the total power consumption of the sensor dictates the conductor size.

S 8	S 9	S 10	Baud rate	Cable length	Number of pairs and conductor size [mm <sup>2</sup> ]
OFF	ON	OFF	250 kBit/s	125 m	2 x 2 x 0.34
<b>Factory setting</b>					
ON	ON	OFF	125 kBit/s	250 m	2 x 2 x 0.5
OFF	OFF	ON	100 kBit/s	335 m	2 x 2 x 0.75
ON	OFF	ON	50 kBit/s	500 m	on request, dependent on bus configuration
OFF	ON	ON	20 kBit/s	1000 m	
ON	ON	ON	10 kBit/s	1000 m	

The baud rate is set via a code switch. Reduce baud rate if cable is longer than specified in the table. Make sure that all bus nodes have the same settings.

To protect the switching contacts fuse circuit with 2.5 A (anti-surge fuse) or according to TRD regulations (1.0 A for 72 hrs operation).

**Note: If the cable is longer than 125 m (max. 1000 m!) the baud rate must be changed.**

Level Limiting  
With CAN Bus, CANopen Protocol  
**NRG 16-40, NRG 17-40,  
NRG 19-40**

**Technical Data** *continued*

**Indicators and adjustors**

One 10-pole code switch for node ID and baud rate settings

One wire link (for switching between electrode 1 and electrode 2)

**Electric connection**

M 12 sensor connector, 5 poles, A-coded,

M 12 sensor jack, 5 poles, A-coded

**Protection**

IP 65 to DIN EN 60529

**Max. admissible ambient temperature**

70 °C

**Weight**

Approx. 2.5 kg

**Order and Enquiry Specification**

GESTRA Level Electrode Type NRG 1...-40

**Associated Controller**

■ Level switch type NRS 1-40

■ Level switch type NRS 1-40.1

**Ancillary Unit**

■ Visual display unit type URB 1, URB 2

**Key**

- 1 Flange PN 40, DN 50  
Flange PN 40, DN 100  
Flange PN 160, DN 80  
Flange PN 250, DN 80  
Flange PN 320, DN 80
- 2 For the approval of the boiler standpipe with connecting flange the relevant regulations must be considered.
- 3 Vent hole
- 4 High water (HW)
- 5 Electrode rod  $d = 8 \text{ mm}$
- 6 Protection tube DN 80
- 8 Electrode distance  $\geq 14 \text{ mm}$
- 9 Low water (LW)
- 10 Reducer DIN 2616-2, K-88.9 x 3.2 - 42.4 x 2.6 W
- 12 Solenoid valve

**PED (Pressure Equipment Directive)**

The equipment complies with the requirements of the Pressure Equipment Directive 2014/68/EU. Applicable in fluids of group 1 and 2. With CE marking, except for equipment according to section 3.3 of the PED.

**ATEX (Atmosphère Explosible)**

According to the European Directive 2014/34/EU the equipment must **not** be used in explosion-risk areas.

Supply in accordance with our general terms of business.

**Dimensions**

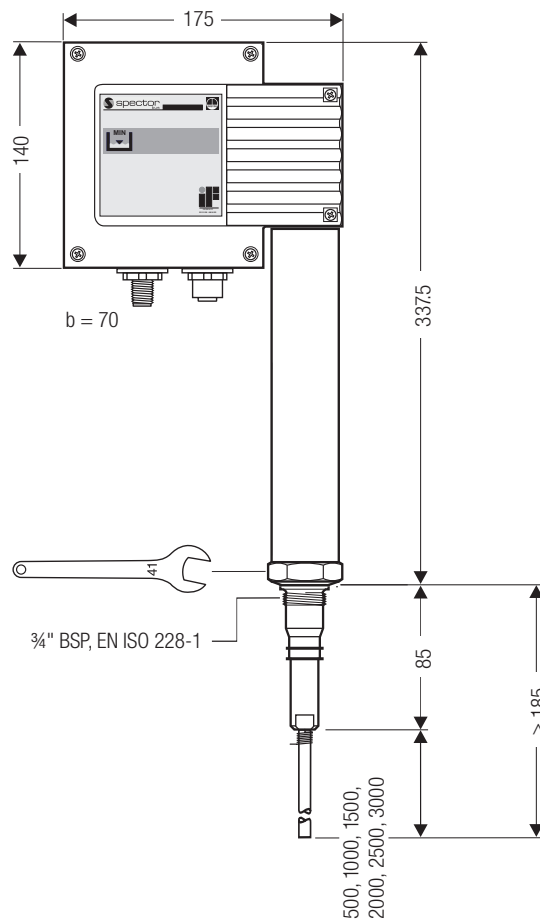

**Fig. 1** NRG 1...-40

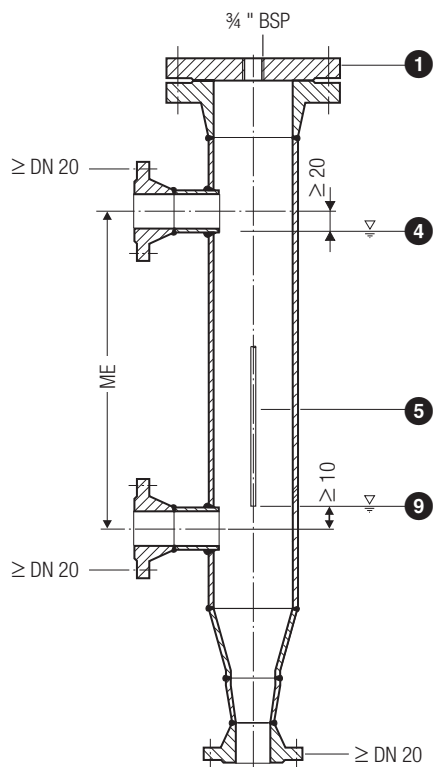

**Fig. 2** External measuring pot

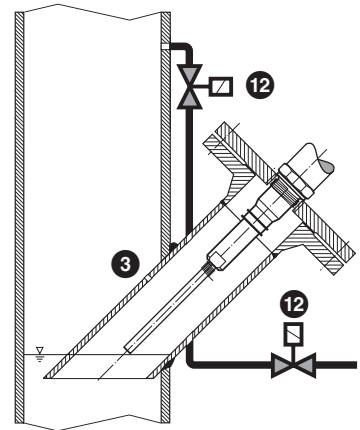

**Fig. 3** Example of a real-function check in a rising feed main of a pressurized hot-water boiler

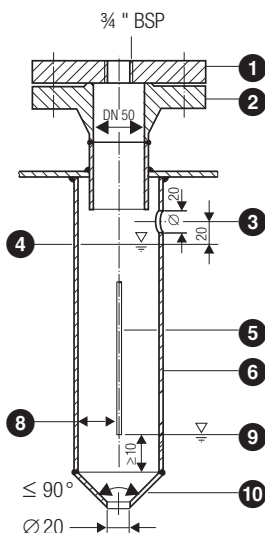

**Fig. 4** Protection tube for installation of electrode inside the boiler

**GESTRA AG**

Münchener Straße 77, 28215 Bremen, Germany  
Telefon +49 421 3503-0, Telefax +49 421 3503-393  
E-mail info@de.gestra.com, Web www.gestra.de

